

Prodo-Pak RV Series

RV-165 • RV-205 • RV-225

SERVO VERTICAL FORM / FILL / SEAL MACHINES

RV-165

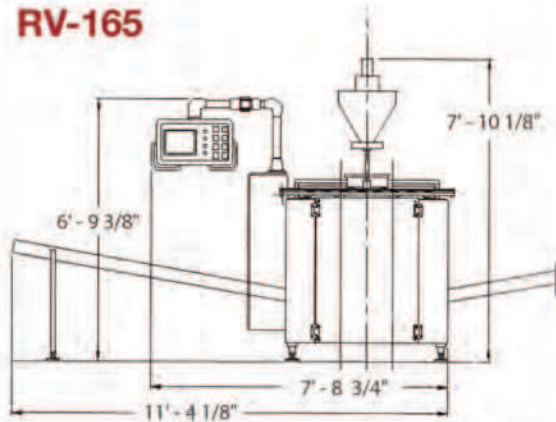

RV-205

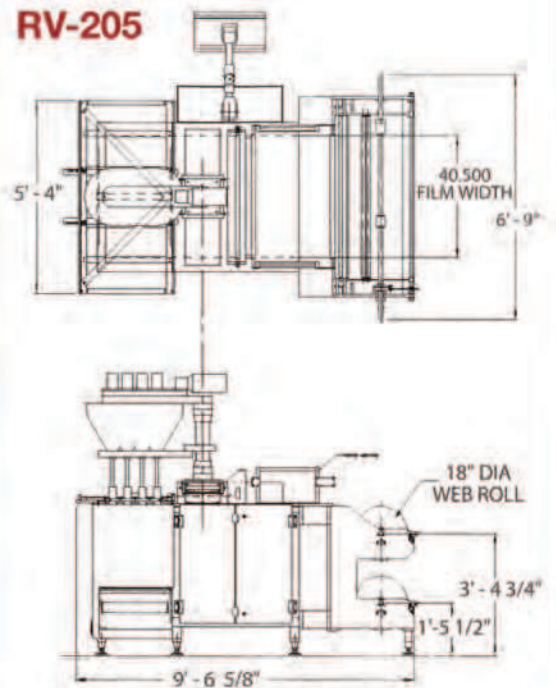

The PRODO-PAK Model RV Series is Designed, Manufactured and Serviced by American Crafts people for the Highest Quality in product packaging. Applications include Tablets, Capsules, Candies, Medical devices, Swabs and Towelettes. Ideal for "Free flowing and Non-free flowing" Powders and Granular products.

UTILITIES

ELECTRICAL: 208/220V, 3 Phase, 60Hz
30 Amp Service
Dependent on Options

SPECIFICATIONS

- Maximum Web Width 50 Inches
- Maximum Roll Diameter 18 Inches
- Film Web Cores 3" to 6"
- Cycle Speed to 150 Per Minute
- Minimum Pouch Width 0.50 inches
- Minimum Pouch Length 1.0 inches
- Maximum Pouch Width 22.5 inches
- Maximum Pouch Length (Infinite)
- Servo Driven Rotary Seal Dies
- Servo Driven Cutting Dies
- Microprocessor Machine Control

OPTIONAL ACCESSORIES

- Volumetric Slide Gate and Cup Fillers
- Tablet and Capsule Feeders
- Net Weight Scales
- Auger Fillers
- Swab and Pad Feeders
- Positive Displacement Piston Pumps
- Slitter and Perforators
- Hole Punches
- Tear Notchers
- Coders and Printers
- Photoelectric Print Registration, One or Both Panels
- Special Design, Custom Feeders
- Die Cut Pouch Shapes
- Servo Driven In-Line Flexo Printer

Note: Dimensions shown are for basic space required, and are approximate.